

ARTEMIS

Perfect imperfection



Our values/

Made in Italy

Selezioniamo le migliori materie prime e, secondo canoni estetici e funzionali, le trasformiamo in prodotti che interpretano con creatività il gusto italiano. Utilizziamo in uguale misura passione e tecnologia, cura del dettaglio e precisione, chimica e cultura, estetica e attenzione all'ambiente. Per noi Made in Italy è racchiudere tutto questo in ogni singolo prodotto.

Made in Italy

We pick the very best raw materials and we follow aesthetics and functional criteria to turn them into products embodying Italian taste and excellence. We sharply combine passion and technology, creativity and accuracy, science and culture, and environmental friendliness. To all of us, Made in Italy means gathering these features into every single product.

Greenthinking

Recuperiamo il 100% dell'acqua, autoproduciamo il 65% dell'energia, differenziamo il 98% dei rifiuti. Siamo stati i primi del settore ceramico a ottenere la certificazione PEF e tra i primi a guadagnarci l'EPD, la FDES e la HPDC. La maggior parte dei nostri prodotti è compatibile con lo standard LEED - Leadership in Energy and Environmental Design. Questo per noi è Greenthinking: un promessa molto seria, un impegno quotidiano.

Greenthinking

We recycle 100% of our water, produce 65% of our energy, separate 98% of our waste. We were the first company in the ceramic industry to obtain PEF certification and were among the first to earn the EPD, the FDES, and the HPDC certifications. The majority of our products comply with the LEED - Leadership in Energy and Environmental Design - standard. Greenthinking implies a solemn promise, an everyday commitment.

GRES PORCELLANATO
PORCELAIN STONEWARE

Effetto pietra
Stone effect

ARTEMIS

Perfect imperfection



PERFETTA
IMPERFEZIONE



ISPIRAZIONE/ INSPIRATION

Perfetta imperfezione

Artemis esprime una sensibilità artistica e scultorea in cui si ritrovano tracce antiche ed elementi dei nostri giorni. Screziature marmoree e ciottoli colorati si avvicinano, intrecciano e fondono; memoria e visione parlano attraverso una superficie d'arredo su cui trovano spazio mondi materici diversi, combinati in un effetto pietra dalla doppia anima, distrattamente chic.

Perfect imperfection

Artemis reveals an artistic and sculptural sensitivity, bringing together antique marks and modern-day elements. Marble specks and colored pebbles intertwine and overlap; memory and vision speak through a furnishing surface on which different material worlds find their place and melt into a casually-chic patina with a dual personality.



INDOOR

120x120 9 mm

60x120 9 mm

30x120 9 mm

80x80 9 mm

40x80 9 mm

5
FORMATI/
SIZES

1
SPESSORE/
THICKNESS

Formati e spessori

Cinque formati per interni fanno di Artemis un contenitore di idee compositive agili e interessanti, sia per pavimenti che per rivestimenti. La scala di grandezze - dal formato 40x80 cm fino al 60x120 e 120x120 cm - arriva fino a dove l'immaginazione architettonica può spingersi.

Sizes and thickness

Five sizes make Artemis a container for agile and engaging compositional ideas, both for indoor floors and walls. The range of sizes - from the 40x80 cm up to the 60x120 and 120x120 cm format - goes as far as the architectural imagination allows it.



5 COLORI/ COLORS

1 SUPERFICIE/ SURFACE

Colori e superfici

La superficie di Artemis, in finitura R9, si tinge di Anthracite, White, Grey, Beige e Silver. Le cinque nuance sprigionano un vigore pacato sul mix grafico di elementi retrò e contemporanei: l'anima marmorea, con i suoi ciottoli e segni di usura, si amalgama con il fondo, compatto e solcato da vene delicate.

Surfaces and colors

The Artemis surface, in R9 finish, shines in White, Anthracite, Grey, Beige, and Silver. The five nuances spread a soft strength over the graphic mix of retro and contemporary elements: pebbles and signs of wear of the marble stone blend with the tile's compact background, furrowed by delicate veins.

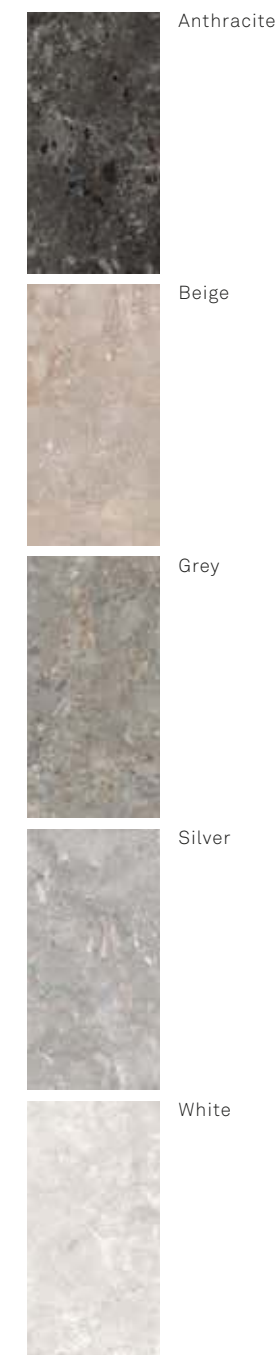

Anthracite

Beige

Grey

Silver

White

anthracite

*Il grigio si fa profondo, prende una tinta plumbea, corposa. L'intensità delle superfici marmoree
aumenta, rischiarata da screziature smaglianti e imprevedibili /
The gray gets deep. Its deep and full-bodied hue boosts the most exquisite marble textures' intensity,
all finished by dazzling and unpredictable streaks.*

120x120 (48"x48")





120x120 (48"x48")

artemis anthracite

120x120 (48"x48")



artemis anthracite

beige

*Un mix delicato e vibrante di pigmenti affini aspetta solo l'incontro con la luce per ammorbidire le atmosfere indoor: via libera a zone relax e lounge in cui soggiornare a lungo /
A delicate yet vibrant mix of pigments looks forward to receiving light. Their presence brings a quiet atmosphere into enchanting lounges to stay in for long*

60x120 (24"x48")



60x120 (24"x48")



artemis beige



60x120 (24"x48")



60x120 (24"x48")

artemis beige

grey

Colore dal carattere schietto, versatile per natura. Suggestisce immediatamente atmosfere new classic, ispirazioni moderniste e industriali influenzate dallo stile mediterraneo / Frank character, naturally versatile. Its Mediterranean style instantly recalls new-classic atmospheres as well as modernist and industrial influences

120x120 (48"x48")

IKON GREY
120x278 (48"x110")

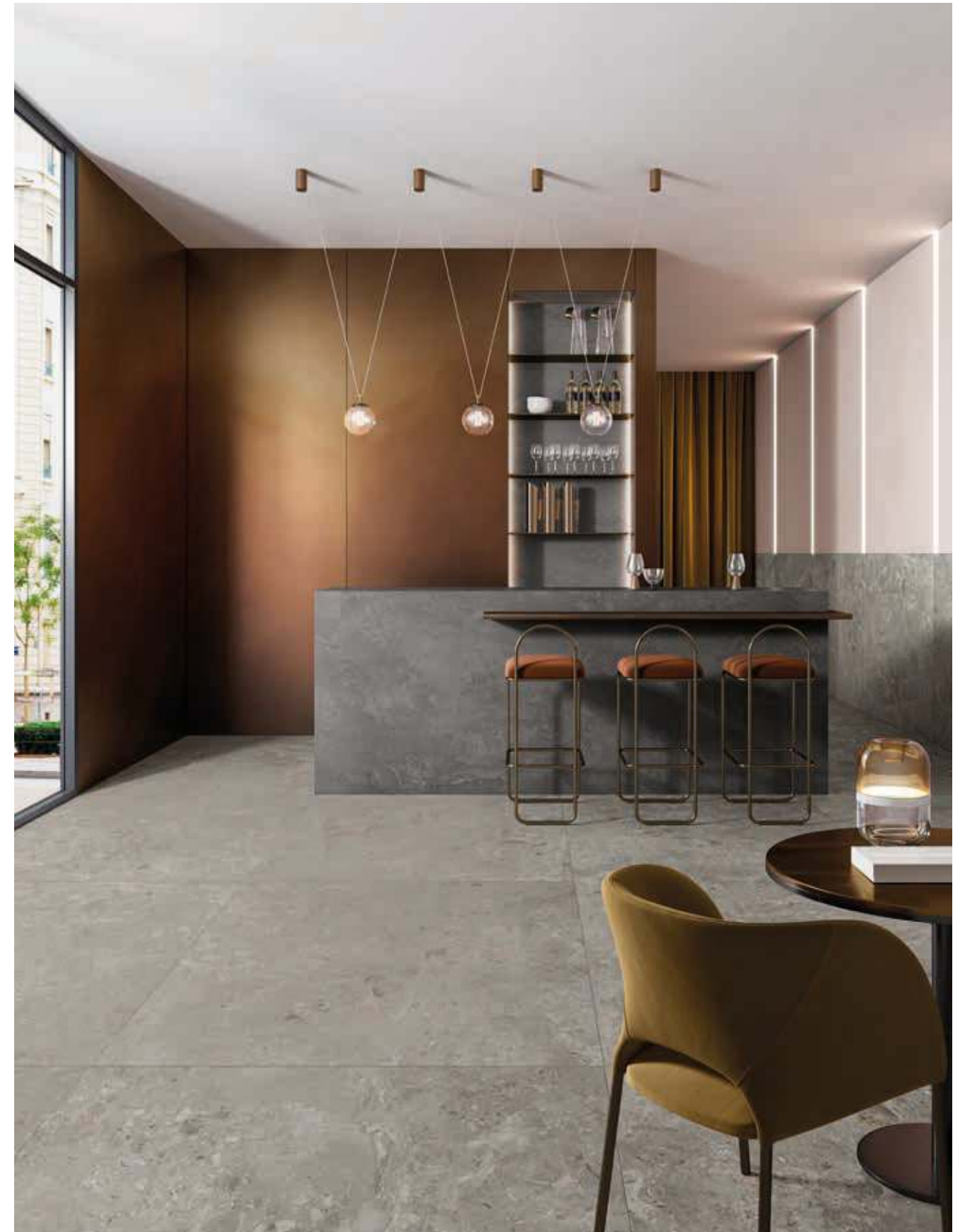



120x120 (48"x48")

artemis grey

120x120 (48"x48")

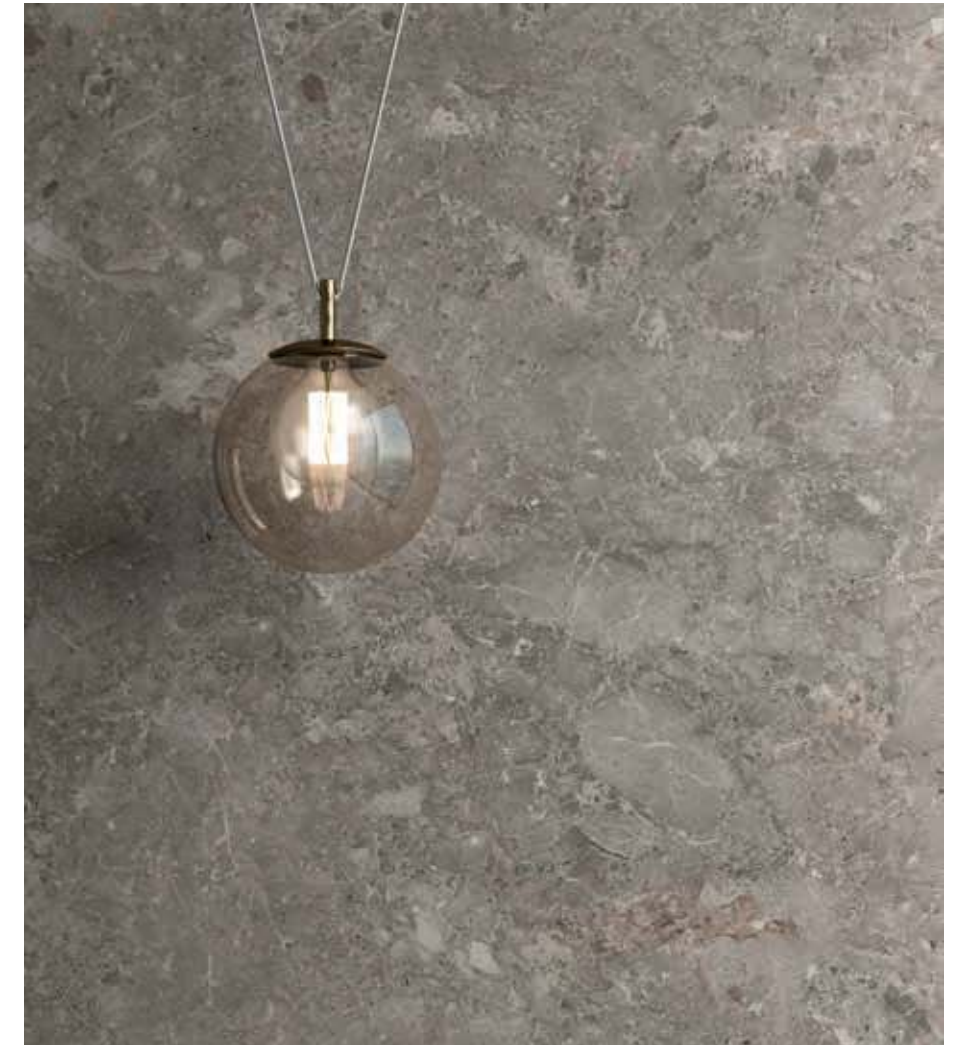

120x120 (48"x48")

artemis grey

silver

Bagliori argentei e tracce rosate portano un fascino quasi lunare sul suolo ceramico. Dentro camere, atri e salotti, i volumi appaiono più leggeri, fluttuanti / Silvery flashes and pink traces bring a lunar charm to the ceramic soil. Inside bedrooms, lobbies, and chambers, all volumes appear lighter, almost fluctuating

80x80 (32"x32") - 40x80 (16"x32")



40x80 (16"x32")



artemis silver



80x80 (32"x32")

80x80 (32"x32") - 40x80 (16"x32")



artemis silver

white

*Candida e lucente, la pietra avvolge in un'aura soave gli ambienti.
Tutto prende subito un sapore nordico e, al tempo stesso, rivela un'eco mediterranea /
Candid and shiny, the stone wraps the rooms in a soothing aura. Walls and floors
immediately take on a Nordic flavor while revealing, at the same time, a clear Mediterranean echo*

60x120 (24"x48")
120x120 (48"x48")





120x120 (48"x48")

artemis white

60x120 (24"x48")



artemis white

HOME DECOR



LAVELLO A COLONNA
COLUMN SINK



DISPONIBILE IN / AVAILABLE IN
50x50x85 cm

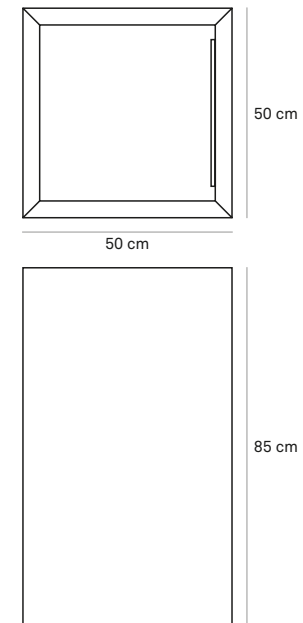

LAVELLO DA APPOGGIO
COUNTERTOP SINK



DISPONIBILE IN / AVAILABLE IN
35x50x8,5 cm

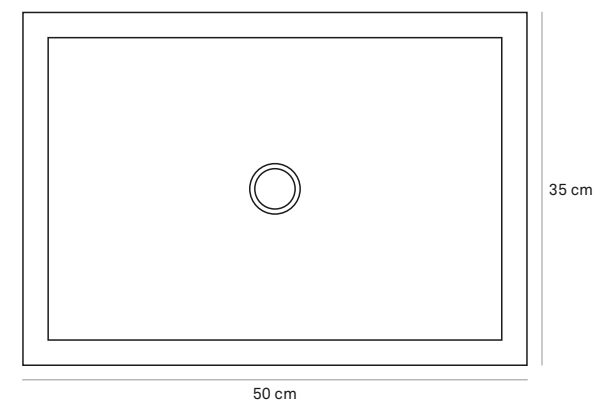

DISPONIBILE IN / AVAILABLE IN
50x120x9 cm

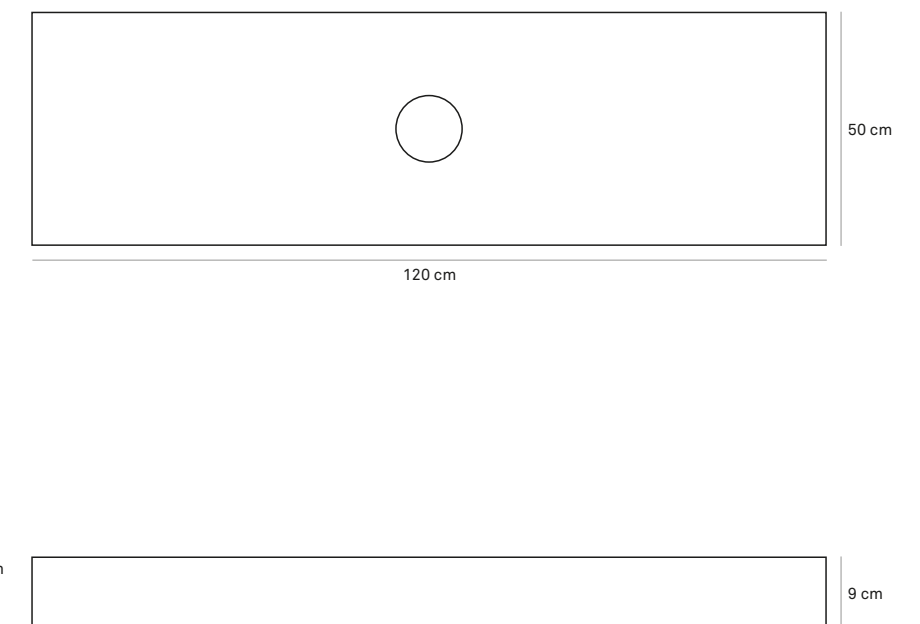

HOME DECOR



PIATTO DOCCIA*
SHOWER TRAY



DISPONIBILE IN / AVAILABLE IN
80x120 cm

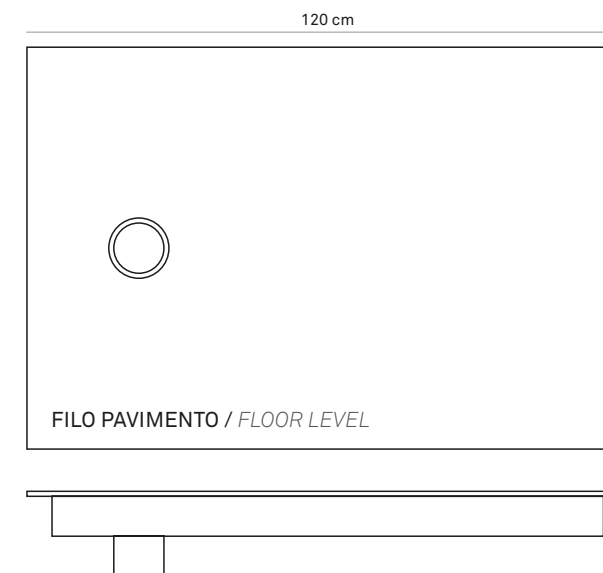

DISPONIBILE IN / AVAILABLE IN
80x120x4 cm

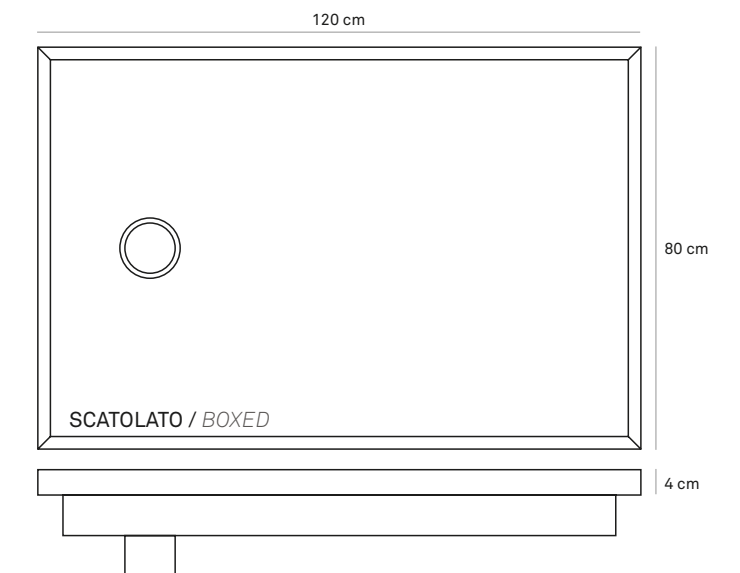

TAVOLINO CIRCOLARE
CIRCULAR TABLE



DISPONIBILE IN / AVAILABLE IN
Ø 42 cm H 50 cm
Ø 58 cm H 50 cm
Ø 73 cm H 39 cm

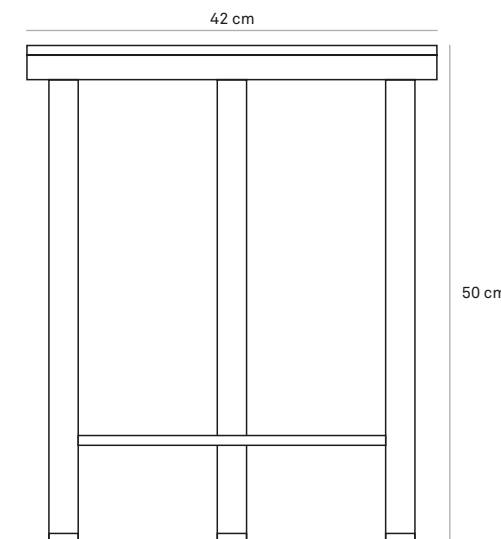

IT_
***Attenzione.** Per ottenere una superficie antiscivolo nel piatto doccia è necessario stendere un tappeto idoneo ad assicurare una presa sicura del piede in presenza di acqua.

EN_
***Warning.** To obtain a non-slip surface in the shower tray it is necessary to lay down a carpet suitable to ensure a secure grip of the foot in the presence of water.

ARTEMIS

SPECIFICHE TECNICHE/ TECHNICAL FEATURES

GRES PORCELLANATO TUTTA MASSA UGL
FULL-BODY PORCELAIN UGL

SPESSORI
THICKNESS

9 mm (120x120 - 60x120 - 30x120 - 80x80 - 40x80)

STONALIZZAZIONE
SHADING



CLASSIFICAZIONE ANTISDRUCCIOLO
ASSESSMENT OF SLIP RESISTANCE

DIN 51130 R9

DIN 51097 A

COF Conforme/*Compliant*

DCOF Conforme/*Compliant*

PENDULUM + 36 PTV 96 -

GRES PORCELLANATO / PORCELAIN STONEWARE



INATTACCABILE DA ACIDI /
NOT ATTACKED BY ACIDS



FACILMENTE PULIBILE /
EASY TO CLEAN



ANTISDRUCCIOLO /
ANTI-SLIP

*per ambienti bagnati e outdoor /
for outdoor and wet environments*



NON REAGISCE AL FUOCO /
DOES NOT REACT TO FIRE

*non emette fumi in caso di incendio /
does not release fumes in case of fire*



RESISTENTE A GELO E SHOCK TERMICI /
RESISTANT TO FROST AND SUDDEN THERMAL CHANGES



RESISTENTE A SFORZI ED ABRASIONI /
RESISTANT TO STRESSES AND ABRASION

*500 Kg/cm² di pressatura meccanica e cottura a 1.250°C /
500 kg/cm² of mechanical pressing and firing at 1250°C*



STABILE CROMATICAMENTE /
CHROMATICALLY FAST

*inalterabile da agenti atmosferici e smog /
unchanged by weather agents and smog*



ASSORBIMENTO H₂O NULLO /
NULL H₂O ABSORPTION

GREENTHINKING / GREENTHINKING



100% ACQUE REFLUE RECUPERATE /
100% RECOVERED WASTE WATER



**98% RIFIUTI AVVIATI A
RACCOLTA DIFFERENZIATA /**
98% WASTE SENT TO SEPARATE COLLECTION



100% PALLET FAO /
100% FAO PALLETS



100% SCARTI CRUDI RECUPERATI /
100% RECOVERED RAW SCRAPS



**ENERGIA AUTO-PRODOTTA DA
FOTOVOLTAICO /**
ENERGY SELF-PRODUCED BY PV PLANT



*** + 5.000.000 L = 3.000.000** 
**ACQUE DI PROCESSO DA ALTRI
STABILIMENTI /**
PROCESS WATER FROM OTHER FACTORIES



*** 18.408 t = 570** 

**MATERIE PRIME NON ESTRATTE
GRAZIE AL RECUPERO DI SCARTI /**
*NON-EXTRACTED RAW MATERIALS THANKS TO THE
RECOVERY OF SCRAPS*



*** + 24.000 MWh/year = 185.000** 
**84% ENERGIA AUTO PRODOTTA DA IMPIANTI
DI COGENERAZIONE /**
84% ENERGY SELF-PRODUCED BY COGENERATION PLANTS

ANTHRACITE



BEIGE



GREY



SILVER



WHITE



V3
STONALIZZAZIONE/
SHADING

ANTHRACITE **V3**



BEIGE **V3**



specs & tech

V3
STONALIZZAZIONE/
SHADING

GREY V3



SILVER V3



WHITE V3



5

FORMATI/ SIZES



● 120x120 (48"x48") RT 9 mm

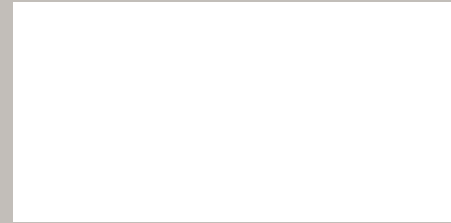

● 60x120 (24"x48") RT 9 mm



● 30x120 (12"x48") RT 9 mm

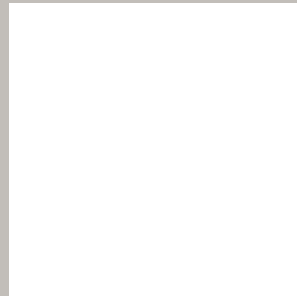

● 80x80 (32"x32") RT 9 mm



● 40x80 (16"x32") RT 9 mm

6

PEZZI SPECIALI/ TRIMS



BATTISCOPA
BULLNOSE

- 4,6x120 (1¹³/₁₆"x48") RT 9 mm
- 7x80 (2³/₄"x32") RT 9 mm

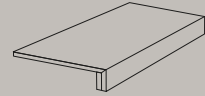

SCALINO CON PROFILO INCOLLATO
GLUED STEP TREAD

- 33x60 (13"x24") RT 9 mm



SCALINO ANGOLARE CON PROFILO INCOLLATO
GLUED CORNER STEP TREAD

- 33x33 (13"x13") RT 9 mm

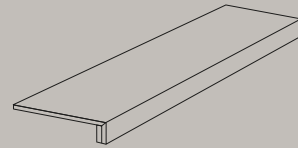

SCALINO CON PROFILO INCOLLATO
GLUED STEP TREAD

- 33x120 (13"x48") RT 9 mm

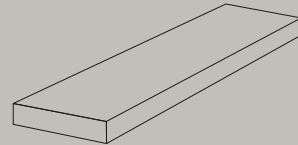

SCALINO ANGOLARE CON PROFILO INCOLLATO
GLUED CORNER STEP TREAD

- 33x120 (13"x48") RT 9 mm

SCHEMI DI POSA/ LAYING SYSTEM

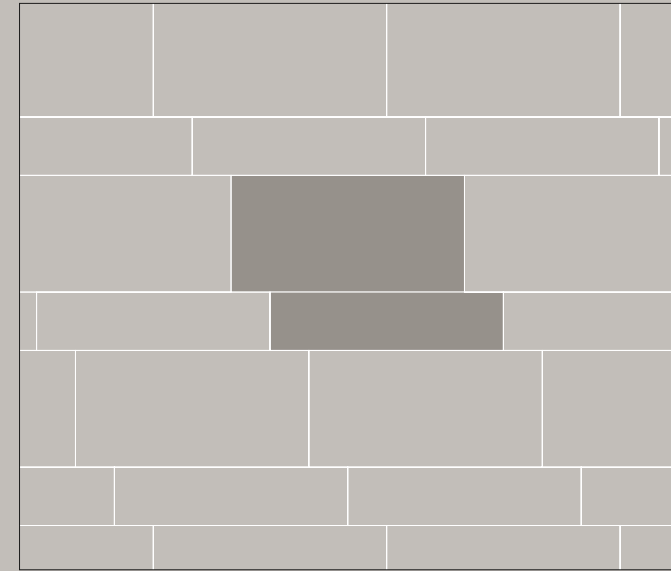

30x120 (12"x48") RT - 33,33%
60x120 (24"x48") RT - 66,66%

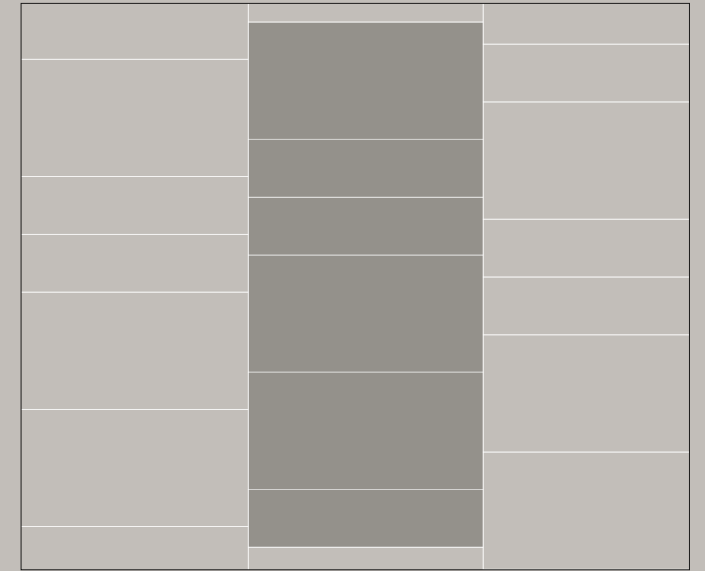

30x120 (12"x48") RT - 33,33%
60x120 (24"x48") RT - 66,66%

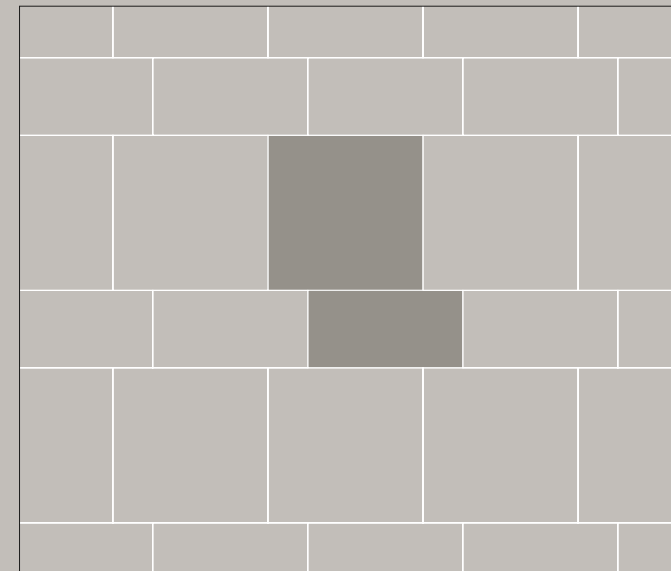

40x80 (16"x32") RT - 33,33%
80x80 (32"x32") RT - 66,66%

Fuga minima consigliata per posa in interno 2 mm, in esterno 4 mm
Minimum suggested joint for indoor laying 2 mm, for outdoor 4 mm
Consigli di posa, pulizia e manutenzione al link keope.com
Consigli di posa, pulizia e manutenzione al link keope.com

● Natural R9

1
FINITURA/
FINISHING



FORMATI
FORMATS

	120x120 (119,5x119,5)* 48"x48"	60x120 24"x48"	30x120 12"x48"	80x80 32"x32"	40x80 16"x32"
working size	1194x1194	596x1195	297x1195	795x795	396x795
	RT	RT	RT	RT	RT
	9 mm	9 mm	9 mm	9 mm	9 mm
ARTEMIS ANTHRACITE	●	●	●	●	●
ARTEMIS BEIGE	●	●	●	●	●
ARTEMIS GREY	●	●	●	●	●
ARTEMIS SILVER	●	●	●	●	●
ARTEMIS WHITE	●	●	●	●	●

*Formato nominale / Nominal size

● Natural R9

MISURE, PESI ED IMBALLI / SIZE, WEIGHT AND PACKAGING

FORMATO SIZE	SPESSORE THICKNESS	PZ/SCATOLA PIECES/BOX	MQ/SCATOLA SQM/BOX	KG/SCATOLA KG/BOX	MQ/PALLET SQM/PALLET	KG/PALLET KG/PALLET	SCATOLA/PALLET BOX/PALLET
120x120	9 mm	2	2,86	60,80	57,12	1.229,00	20
60x120	9 mm	2	1,44	28,66	50,44	1.016,10	35
30x120	9 mm	4	1,44	30,50	51,84	1.111,00	36
80x80	9 mm	2	1,28	25,60	61,44	1.241,80	48
40x80	9 mm	4	1,28	27,36	35,84	779,08	28

INFORMAZIONI TECNICHE / TECHNICAL FEATURES

INFORMAZIONI TECNICHE TECHNICAL FEATURES	NORMA NORM EN 14411 - ISO 13006	REQUISITI PRESCRITTI REQUIRED VALUES	VALORI VALUES			
 DIMENSIONI RETTIFICATO SIZES RECTIFIED	UNI EN ISO 10545-2	lunghezza-larghezza / lenght-width $\pm 0,3\%$ ($\pm 1,0$ mm max) spessore / thickness $\pm 5,0\%$ ($\pm 0,5$ mm max) ortogonalità / rectangularity $\pm 0,3\%$ ($\pm 1,5$ mm max) rettilinearità / straightness $\pm 0,3\%$ ($\pm 0,8$ mm max) planarità / flatness $\pm 0,4\%$ ($\pm 1,8$ mm max) qualità superficie / surface quality $\geq 95\%$	CONFORME COMPLIANT			
 ASSORBIMENTO ACQUA WATER ABSORPTION	UNI EN ISO 10545-3	$\leq 0,5\%$	$\leq 0,1\%$			
 RESISTENZA A ROTTURA BREAKING STRENGTH	UNI EN ISO 10545-4	$R \geq 35$ N/mm ² $S \geq 700$ N (<7,5 mm) $S \geq 1300$ N ($\geq 7,5$ mm)	9 mm CONFORME COMPLIANT			
 RES. ABRASIONE PROFONDA (UGL - Matt) DEEP ABRASION RESISTANCE (UGL - Matt)	UNI EN ISO 10545-6	≤ 175 mm ³	≤ 150 mm ³			
 RESISTENZA SHOCK TERMICI THERMAL SHOCK RESISTANCE	UNI EN ISO 10545-9	resistenza / resistant	CONFORME COMPLIANT			
 RESISTENZA AL GELO FROST RESISTANCE	UNI EN ISO 10545-12	resistenza / resistant	CONFORME COMPLIANT			
 RESISTENZA CHIMICA CHEMICAL RESISTANCE	UNI EN ISO 10545-13	resistenza / resistant	CONFORME COMPLIANT			
 RESISTENZA ALLE MACCHIE RESISTANCE TO STAINS	UNI EN ISO 10545-14	pulibile / cleanable	CONFORME COMPLIANT			
	DIN 51130	R	prodotto / product	R	A+B+C	>0,40 >0,42
	DIN 51097	A+B+C	120x120 - 60x120 - 30x120 - 80x80 - 40x80	R9	A	CONFORME COMPLIANT
 CLASSIFICAZIONE ALTISDRUCCIOLO ASSESSMENT OF SLIP RESISTANCE	B.C.R.A. (COF)	>0,40 bagnato / wet				
	ANSI A137.1 2012 (DCOF)	>0,42 bagnato / wet				
	Pendulum Test Value PTV 96 (R10)	> 36	-			

Piastrelle pressate a secco - Conforme alla norma EN 14411 e ISO 13006 appendice G gruppo B1-a con E $\leq 0,5\%$

Dry pressed tiles - Compliant with standards EN 14411 and ISO 13006 annex G group B1-a with E $\leq 0,5\%$



HEADQUARTER via statale 467, 21
42013 Casalgrande (RE) - Italy
FACTORY via canale, 67
42013 Casalgrande (RE) - Italy
WAREHOUSE via dell'industria, 1
42013 Casalgrande (RE) - Italy

PHONE +39 0522 997511
FAX +39 0522 997544 (OT) - 545 (IT)
ADMIN. FAX +39 0522 997413

info@keope.com
keope.com

IT_

Ceramiche Keope si riserva la facoltà di apportare variazioni ai prodotti illustrati in questo catalogo per necessità produttive o al fine di migliorarne la qualità. I campioni e le immagini sono puramente indicativi. Gli imballaggi e pesi riportati possono variare per necessità produttive. Consultare gli uffici commerciali al momento dell'ordine.

EN_

Ceramiche Keope reserves the right to vary the products illustrated in this catalogue for production purposes or in order to improve quality. Samples and images are purely indicative. Packaging and weights shown may be varied in line with production requirements. Check with the sales department at the time of order.

